



BZE6-2RQ9



Actual product appearance may vary.

Enclosed Switches Series E6: Top Roller Plunger Actuator; 1NC 1NO SPDT Snap Action; 0.5 in - 14NPT conduit

Features

- Side or flange mount
- Momentary or maintained contact
- Grounding screw
- High capacity (22 amp) available
- Temperature range -32 °C to +71 °C [-25 °F to +160 °F]
- Zinc Die-Cast housing NEMA 1
- UL Recognized, file #E12252
- CSA Certified, file #LR41372
- NEMA 1 /IP40
- Pre-leaded or connector termination options

Potential Applications

- Packaging equipment
- Special machinery
- Textile machinery
- Conveyors
- Construction machinery and equipment
- Printing trades machinery
- Overhead cranes and hoists

Description

MICRO SWITCH™ E6 (side mount) and V6 (flange mount) switches are offered with or without actuator seal boots. Both have a combination insulator/seal cemented inside the bottom enclosure. Lead washers are used to seal the mounting holes on side mount switches. All side mount switches are installed with #6 screws, except the BZE6-2RN7 (#8 screws). Removal of the bottom enclosure exposes the terminals for easy wiring.

Product Specifications	
Availability	Global
Operating Force (O.F.)	2,50 N to 3,61 N [9 oz to 13 oz]
Release Force (R.F.)	1,11 N min. [4 oz min.]
Pretravel (P.T.)	0,38 mm [0.015 in] max.
Overtravel (O.T.)	3,55 mm min. [0.140 in min.]
Differential Travel (D.T.)	0,05 mm max. [0.002 in max.]
Product Type	Enclosed Switches
Actuator	Top Roller Plunger
Circuitry	1NC 1NO SPDT Snap Action
Ampere Rating	15 A Ind./2 A Ind./0.5 A Res./0.25 A Res.
Supply Voltage	125 Vac, 250 Vac, 480 Vac/600 Vac/125 Vdc/250 Vdc
Housing Material	Zinc Die-Cast
Termination Type	0.5 in - 14NPT conduit
Housing Type	Split Housing, Side Mount
Series Name	E6/V6
Sealing	NEMA 1 /IP40
Approvals	UL recognized, CSA certified
CSA File #	LR41372
UL File #	E12252
Operating Temperature Range	-32 °C to 71 °C [-25 °F to 160 °F]
Comment	Without seal boot on plunger, Roller parallel to long axis of switch; Field adjustable roller
UNSPSC Code	302119
UNSPSC Commodity	302119 Switches and controls and relays
Sealed	Industrial

MICRO SWITCH
 FREEPORT, ILLINOIS U.S.A
 A DIVISION OF HONEYWELL
 FED. MFG. CODE 91929

SWITCH - ENCLOSED

CATALOG LISTING
BZE6-2RQ9

DRAWING NUMBER: BZE6-2RQ9
 ISSUE: 10
 PSR: 29AUG07
 CHECK: R O B
 REVISIONS:
 A: 38200-B, TMM, 8 SEPT 77
 B: C05319-G, CJH, 2 MAY 84
 C: C055989, JAS, 6 NOV 84
 D: C054958, GJW, 12 MAR 85
 E: C072618, L J F, 11 SEP 92
 F: 0016894, KRB, 10 NOV 05
 G: 0033014, BS, 29AUG07
 DRAWN: RASTER, FO-5281-A, 8 SEPT 77
 CHECK: K P K, 12 SEP 77
 REPLACES: 29AUG07

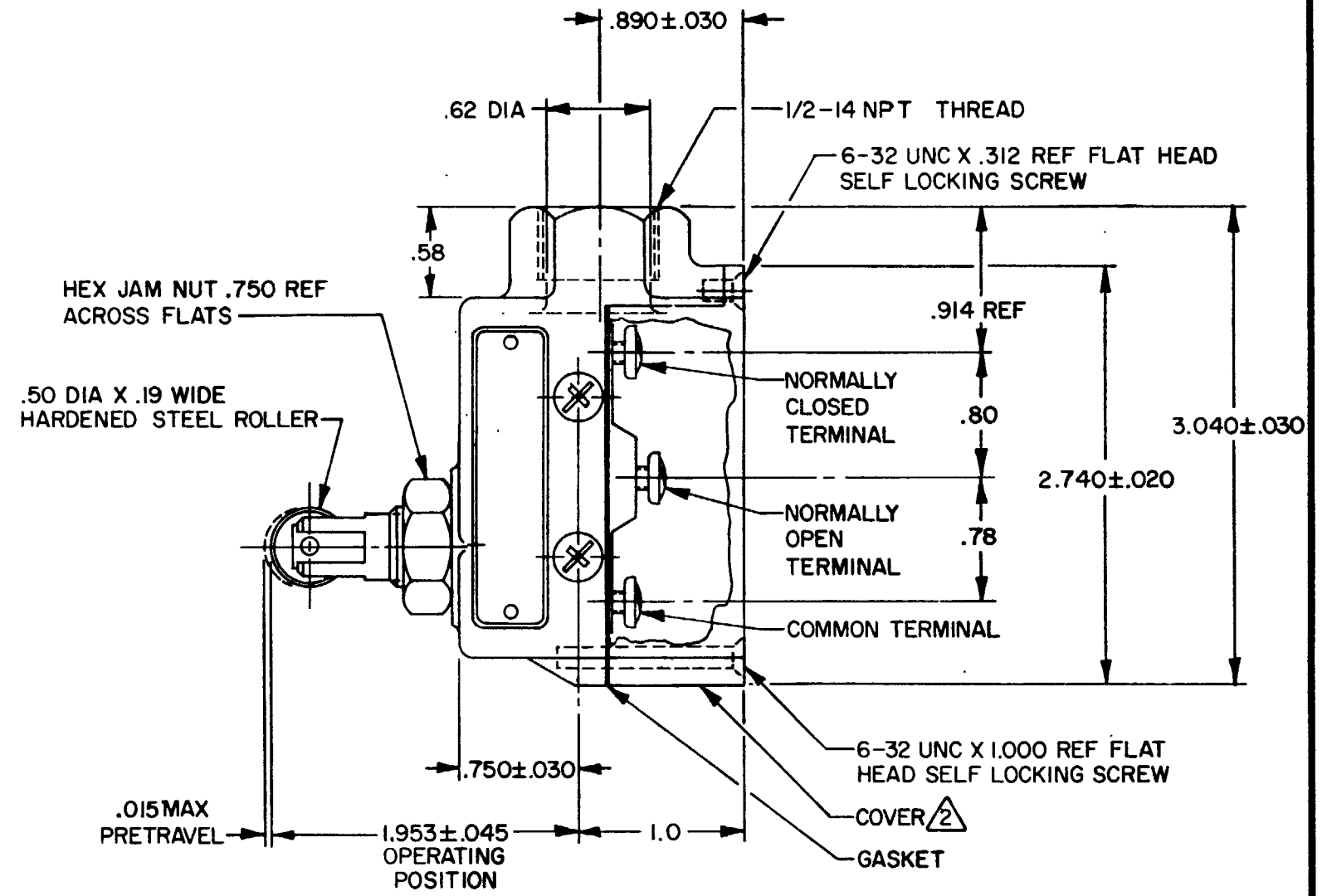
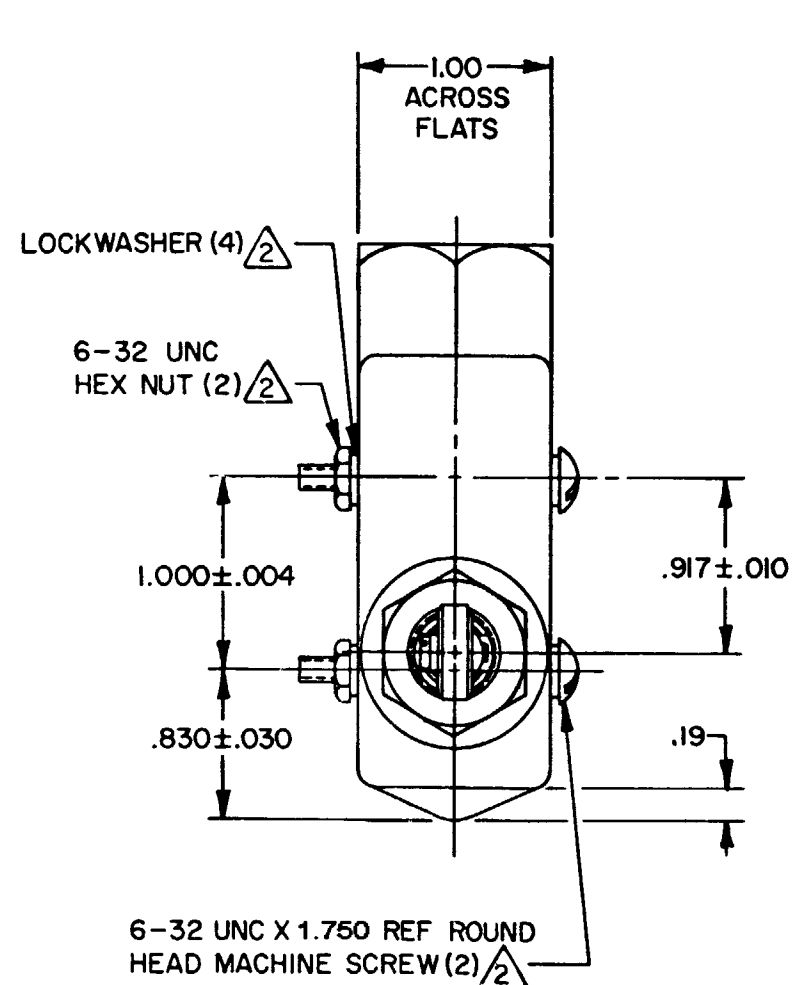

- NOTES -
- 1 - 6-32 UNC X .219 REF BINDING HEAD TERMINAL SCREW AND CUPWASHER (3)
 - 2 - FURNISHED UNASSEMBLED
 - 3 - SEAL RATING: NEMA 1 IP40

THIS DRAWING COVERS A PROPRIETARY ITEM AND IS THE PROPERTY OF MICRO SWITCH, A DIVISION OF HONEYWELL. THIS DRAWING IS NOT TO BE COPIED OR USED WITHOUT THE APPROVAL OF MICRO SWITCH.

CHARACTERISTICS	ELECTRICAL DATA	SCALE FULL
OPERATING FORCE — — 9-13 OZ	CONTACT ARRANGEMENT S P D T	DO NOT SCALE PRINT
RELEASE FORCE — — 4 OZ MIN	15A-125, 250 OR 480 VAC, 2A-600 VAC 1/8 HP-125 VAC; 1/4 HP-250 VAC 1/2A-125 VDC; 1/4A-250 VDC CODE L74	UNLESS OTHERWISE NOTED DIMENSIONS ARE IN INCHES
DIFFERENTIAL TRAVEL — — .002 MAX	CE 1.5A, 240 Vac	TOLERANCES ARE:
OVERTRAVEL — — .140 MIN		ONE PLACE (.0) ± .030 TWO PLACE (.00) ± .015 THREE PLACE (.000) ± .005 ANGLES
BASIC SWITCH REPLACEMENT — BZ-2RQ69	WEIGHT .56 LB	